

TURBOTWISTER™

ASSEMBLY AND INSTALLATION INSTRUCTIONS

S.R. Smith LLC™



**CORPORATE HEADQUARTERS
WESTERN SALES AND MANUFACTURING PLANT
P.O. Box 400 • 1017 SW Berg Parkway
Canby, Oregon 97013
Phone: (503) 266-2231 • Fax: (503) 266-4334
www.srsmith.com**

Table of Contents

Topic

Page

Introduction.....	2
Parts List.....	3
Assembly Instructions.....	4
Manufacturer's Placement Instructions.....	10
Installed Slides' Structural & Installation Checklist.....	12

INTRODUCTION

The TurboTwister™ slide is designed and manufactured for installation and use on swimming pools only. TurboTwister™ slides are NEVER to be installed and used on houseboats, boat docks, floating docks or platforms, or other bodies of water such as lakes, ponds, rivers, etc. Proper and complete assembly, use and supervision is essential for proper operation and to reduce the risk of accident or injury.

IMPORTANT

Check entire boxes and inside all packing materials for parts. Before beginning assembly, read the instructions and identify parts using the figures and parts listed in this document. It is critical that all parts be carefully inspected by the installer prior to installation to ensure that no damage occurred in transit and that a damaged part is not used. Proper installation cannot be overstressed, as an improper installation voids S.R. Smith's warranty and may affect the safety of the user.

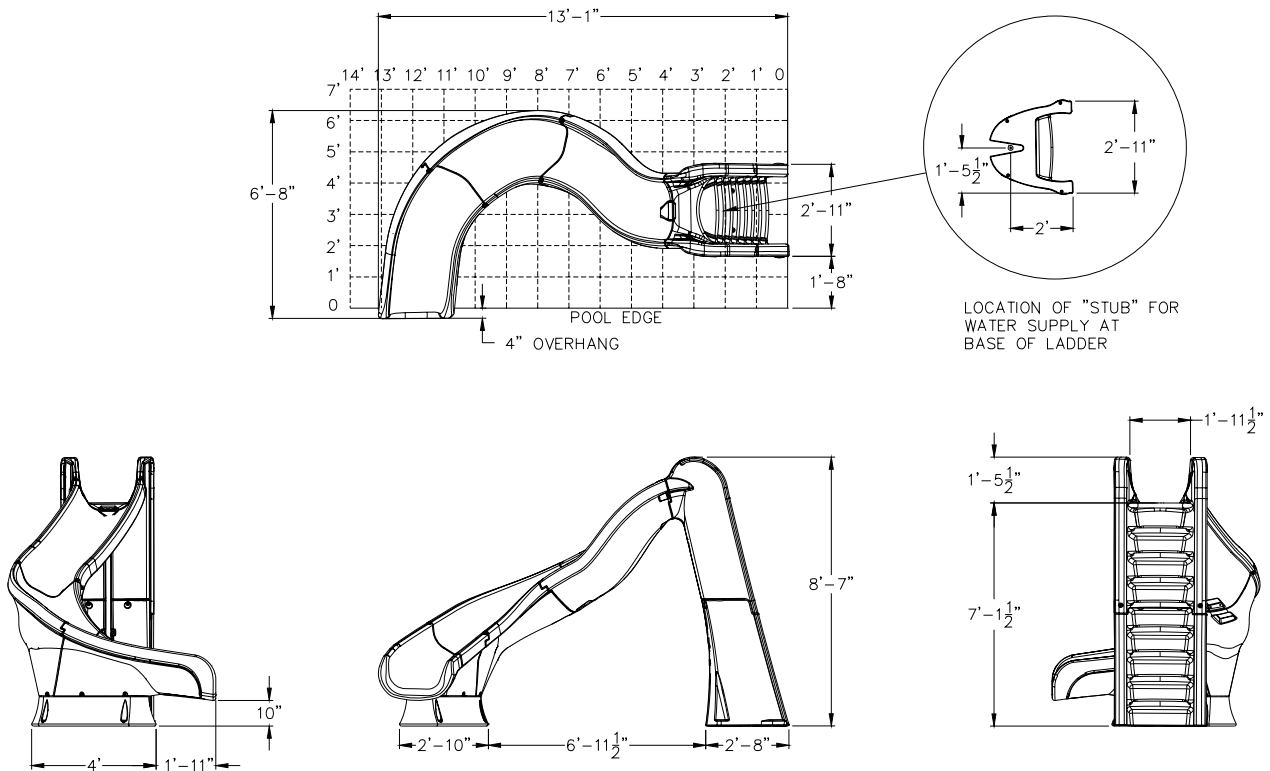

Left curve shown for illustration -
Right curve is a mirror image of the left.

FIG. 1

TURBOTWISTER™ PARTS LIST

ITEM #	PART #	DESCRIPTION	QTY.
1	5-139	3/8" Hex Nut	14 ea.
2	5-151	3/8" Lock Washer	14 ea.
3	05-14-115	1/2" Lock Washer	8 ea.
4	5-145	3/8" Flat Washer	35 ea.
5	5-235	3/8" x 2-1/4" Carriage Bolt	2 ea.
6	5-236	3/8" x 2-1/4" Button Head Cap Screw	4 ea.
7	5-239	3/8" x 2-1/2" Stud	4 ea.
8	5-240	3/8" x 3-1/2" Lag Screw	9 ea.
9	5-237	3/8" x 5" Button Head Cap Screw	4 ea.
10	5-238	3/8" x 6" Hex Head Cap Screw	4 ea.
11	5-242	#14" x 1" Pan Head Tapping Screw	6 ea.
12	5-241	1/2" x 5" Anchor Stud	8 ea.
13	05-782	1.5" PVC Pipe Strap	3 ea.
14	1-305-1	1.5" PVC Sch 80 Pipe, 10" Length	1 ea.
15	1-305-2	1.5" PVC Sch 80 Pipe, 47-5/8" Length	1 ea.
16	05-777	1.5" Ball valve	1 ea.
17	05-778	1.5" PVC 45-deg Elbow	2 ea.
18	05-781	1-1/2" Coupling	1 ea.
19	05-780	1-1/2" x 3/4" Reducer	1 ea.
20	05-779	Garden Hose Adapter	1 ea.
21	4-610	Shim	3 ea.



(1)



(2)



(3)



(4)



(5)

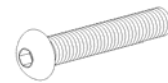

(6)

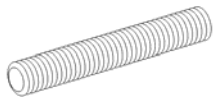

(7)



(8)

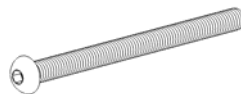

(9)



(10)



(11)



(12)

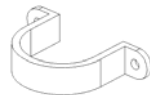

(13)



(14)



(15)

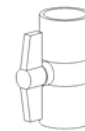

(16)



(17)



(18)



(19)



(20)



(21)

ASSEMBLY INSTRUCTIONS

Tools Required:

1. Ratchet handle
2. 9/16" deep socket
3. 9/16" wrench
4. 1/2" socket or wrench
5. 7/32" allen wrench
6. Phillips head screwdriver
7. 1/2" concrete drill bit
8. 1/4" drill bit
9. Power drill
10. PVC pipe primer & glue
11. Anti-seize
12. Saw to cut PVC pipe
13. Knife

- Gasket material has been supplied for use at the connections/joints of the slide sections.
- Apply gasket in the required locations as shown in the figures below.
- Place gasket along the section to determine the length needed.
- Cut gasket to appropriate length.
- Remove backing and adhere gasket to slide

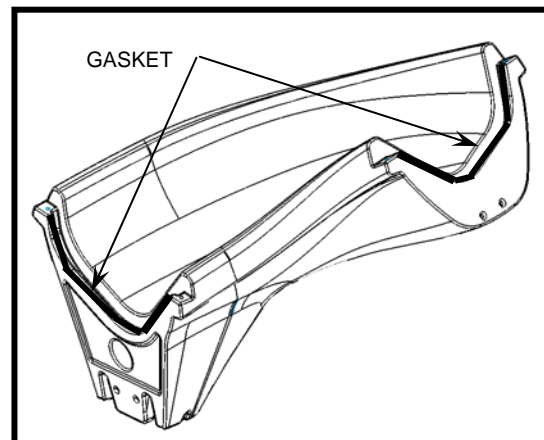
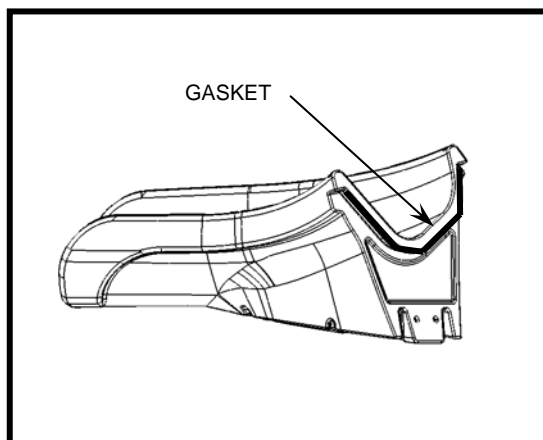
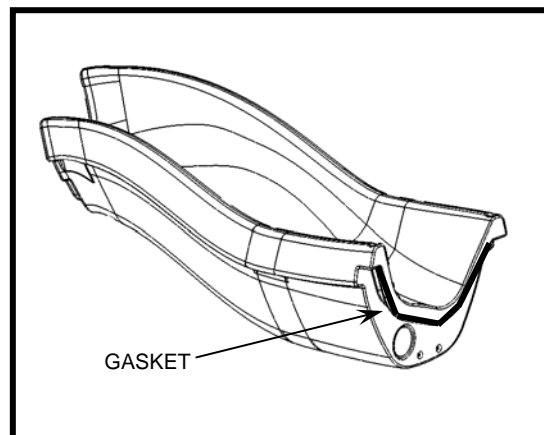
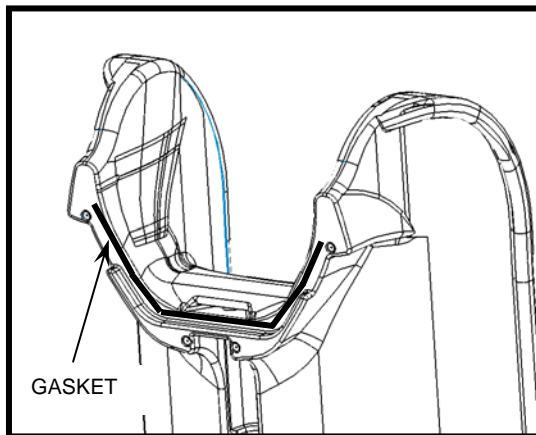

1. Place the pedestal on the ground and set the exit slide section on top.

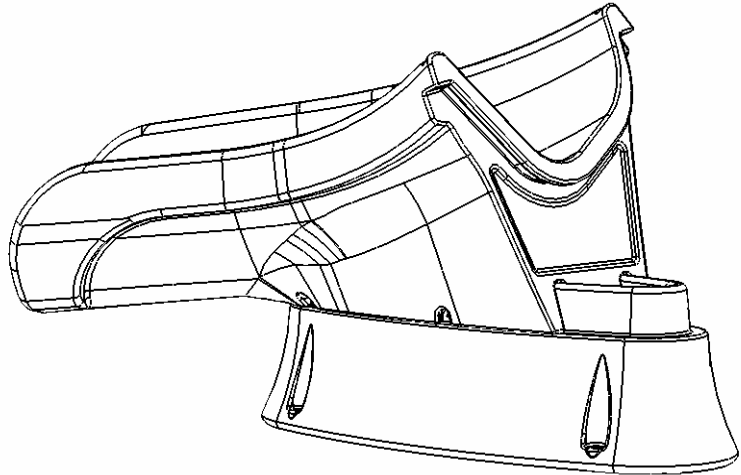

2. Attach the exit slide section to the middle slide section using the hardware shown.

Note: *Ensure gasket material at the joint is intact before assembling.*

NOTE: When assembling the slide, apply a thin even coating of anti-seize to all stainless steel fasteners. Anti-Seize helps aid in assembly, prevents galling and aids in corrosion resistance

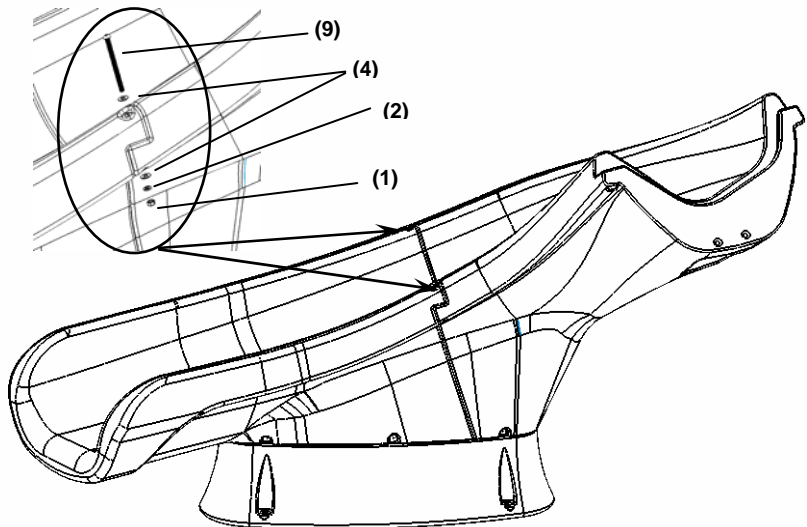

3. Remove the assembled exit and middle slide sections from the pedestal. Turn over and fasten from the underside as shown.

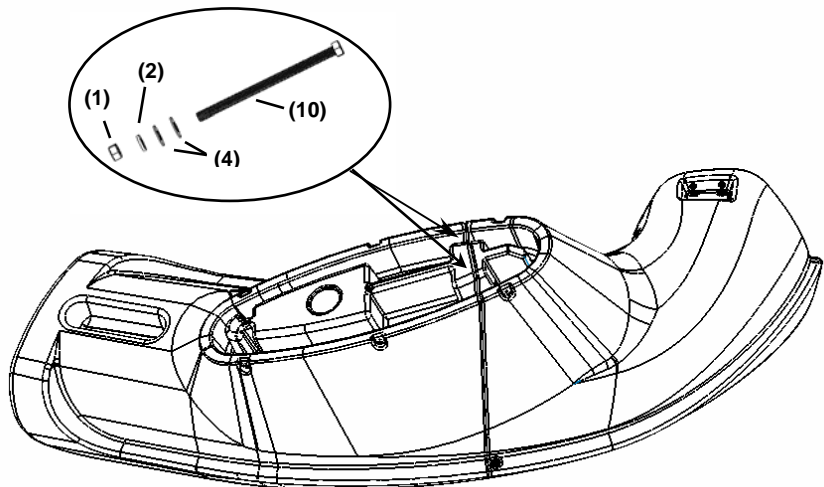

4. Attach the pedestal to the middle and exit slide sections as shown in (3) locations.

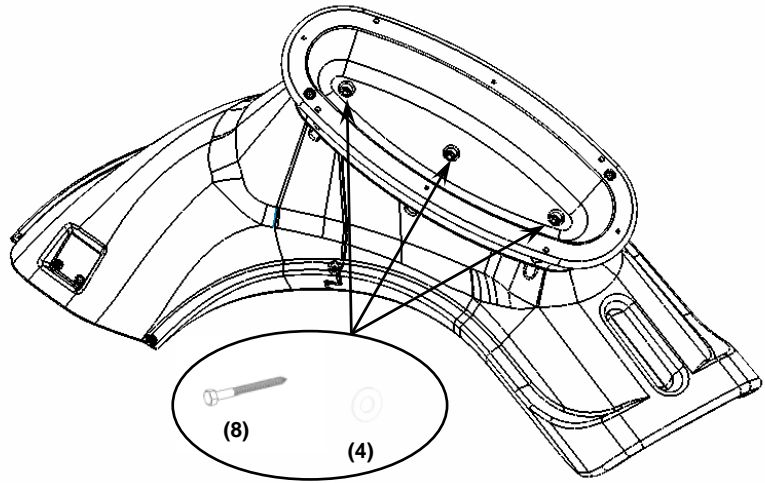

5. Install the 3/8" studs into the threaded inserts in the top of the ladder as shown in (4) locations.

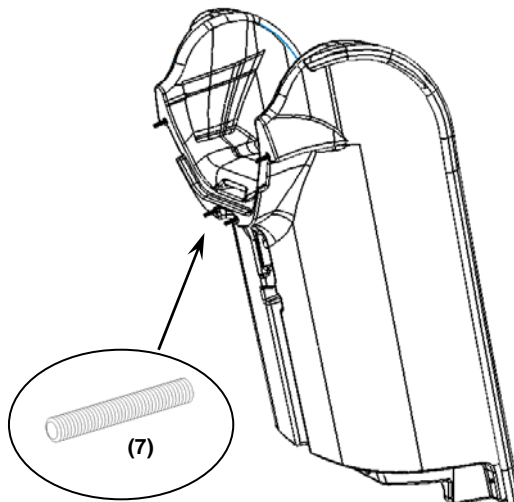

6. Assemble the top and bottom ladder sections as shown.

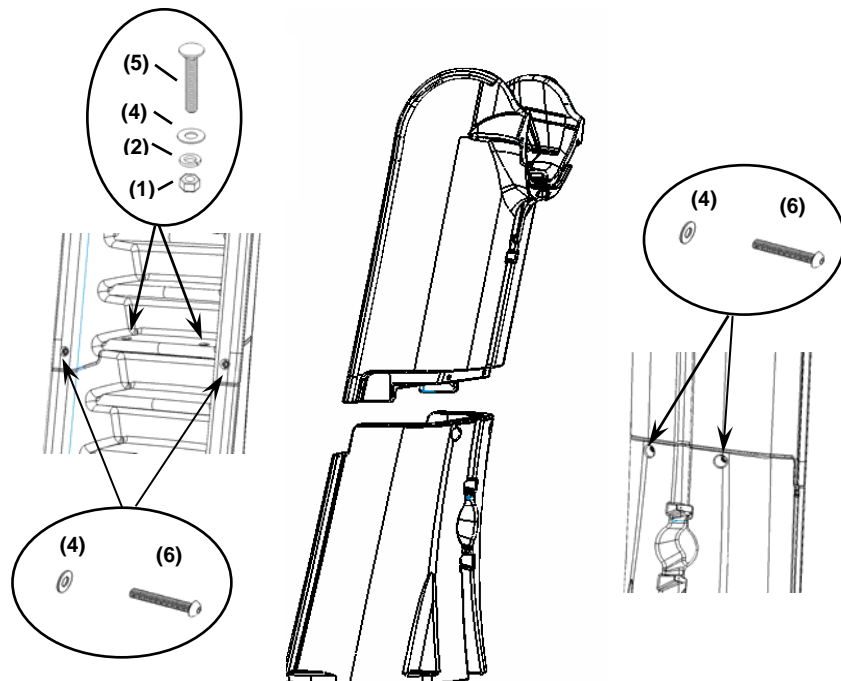

7. Lay the ladder flat and attach the top slide section as shown. Use the appropriate hardware in 4 places.

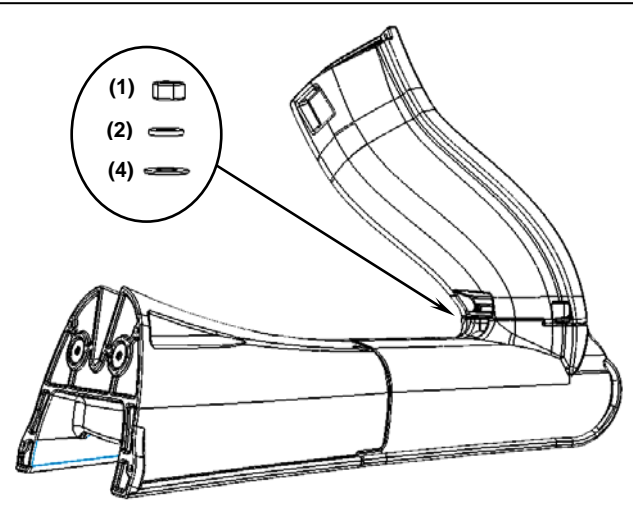

8. Stand the ladder upright and assemble the slide components as shown.

Note: Ensure gasket material at the joint is intact before assembling.

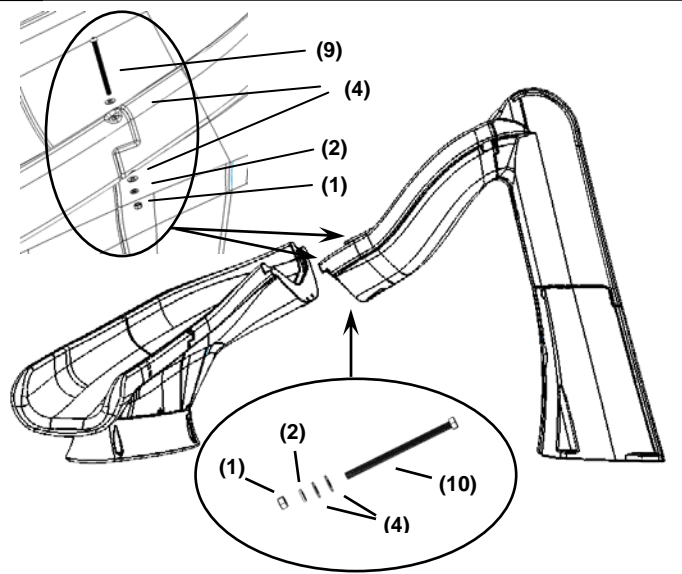

9. Attach the base unit as shown in (6) locations. Mark and drill a 1/4" pilot hole in the center of each recess before fastening with the lag screws.

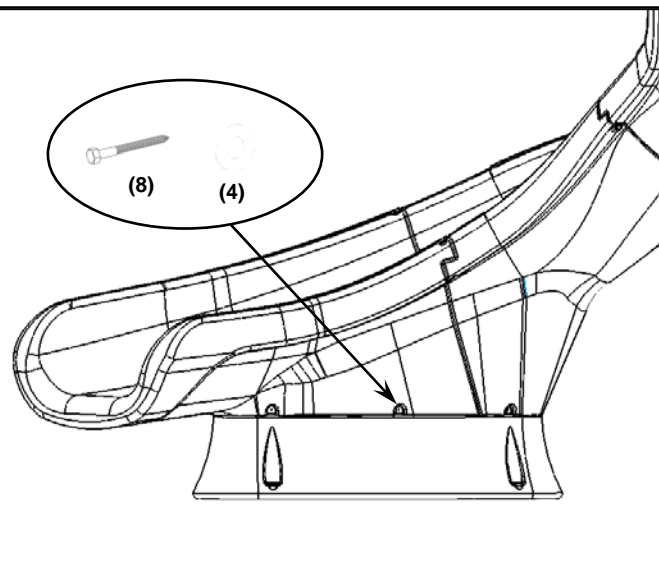

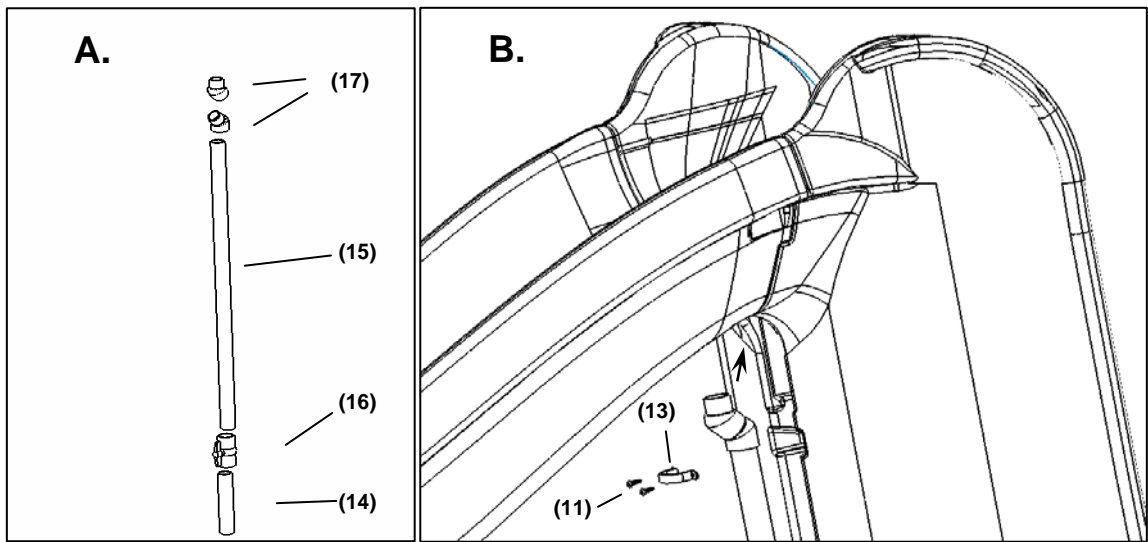

10. Assembly of Water Supply Plumbing Parts:

- Assemble parts as shown in Step “A” without glue to make sure alignment of elbows is in line with the ball valve. Place plumbing assembly in slide ladder to check fit before proceeding.
- Mark alignment of parts with a pencil before disassembling. This will aid in reassembling parts when gluing.
- Use PVC primer and glue to assemble plumbing parts as shown in Step “A” above.
- Glue assembled water supply pipe to the 1.5” PVC fitting installed in the ladder as shown in Step “B”.

PLUMBING INSTRUCTIONS

1. The TurboTwister is designed for a water supply line of 1-1/2” pipe. Plumb from pool return line with a 1-1/2” PVC pipe “stubbed up” at the deck positioned at the base of the ladder. Refer to **FIG. 1** on page 2. **FIG. 1** is for reference only. Assembled slide should be placed in its correct location and the “stub up” location marked and installed before mounting the slide to the deck. “Stub up” should be dark grey PVC to match the plumbing assembly of the slide. **Note: “Stub up” should extend above the deck 18” in height. It can be cut to proper length further in the installation process.**

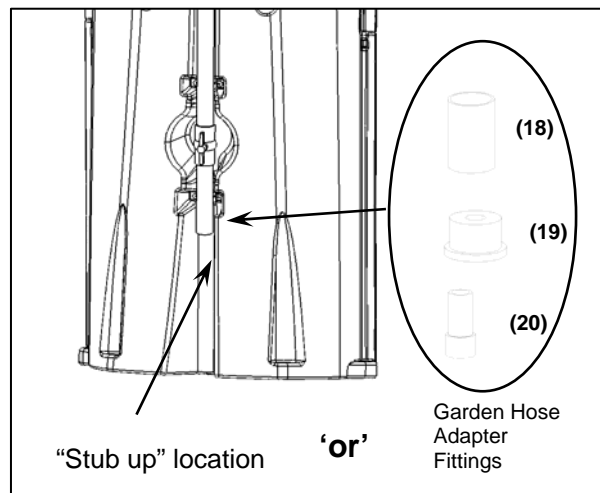

2. If a garden hose is to be used, a garden hose adapter fitting is included with the slide. Assemble the pieces as shown and attach to the end of the PVC plumbing assembly at the base of the ladder.
3. Proceed to the following section for **ON-DECK MOUNTING**. After the slide has been mounted to the deck, attach the “stub up” as necessary to the plumbing assembly installed in the ladder.
4. The TurboTwister can handle up to 35 gallons per minute. Water flow is to be regulated using the ball valve near the base of the ladder.

ON-DECK MOUNTING INSTRUCTIONS

1. Place the assembled slide on the deck relative to the pool wall. Ensure that the exit flume clears any coping. Slide may be angled slightly providing all dimensions are maintained as noted in the **Manufacturer's Placement Instructions** noted in the following section.
2. With the slide in its proper location, center punch or otherwise mark through the (8) mounting holes at the bottom of the ladder and pedestal so that a visible mark is apparent on the concrete.
3. Move the assembled slide aside to facilitate drilling of the anchoring holes.

4. Using a power drill and a 1/2" concrete drill bit, drill the holes to a depth of 4". Use tape or a marking on the drill bit to ensure that the hole for the anchor is drilled to the required depth. Maintain drill hole straight and perpendicular for proper holding strength of anchor stud.

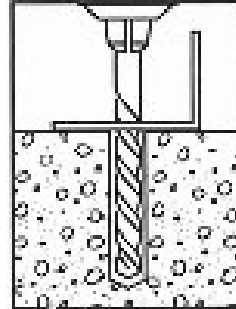

5. Clear the holes of all debris. Assemble anchor with nut and washer so that the top of the nut is flush with the top of the anchor. Move the slide over the holes and insert the anchors. Drive anchor through the slide mounting holes so that nut and washer are flush with the surface material.

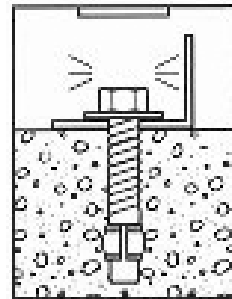

6. Ensure the slide ladder is plumb by placing a level on a ladder tread. If necessary, shims have been provided to place beneath the base of the ladder to ensure it is plumb due to varying deck slopes. Shims may be stacked on top of each other.

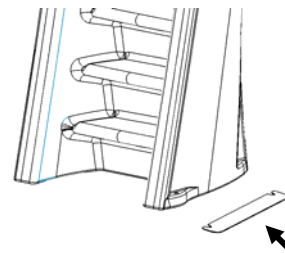

7. Expand anchor by tightening nut 3 to 5 turns. Once anchor is set remove nut and install a lock washer, item # (3), and retighten nut to a torque of 55 ft.-lbs.

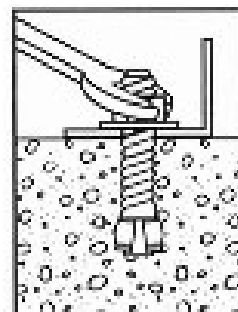

MANUFACTURER'S PLACEMENT INSTRUCTIONS

1. The critical dimensions for placement of the TURBOTWISTER™ are as shown in **FIG.'S 8 and 9**.
 - A. The slide exit runway surface shall not exceed twenty inches (20") above the water surface as shown in **FIG. 8**.
 - B. The slide shall be positioned so that all water flowing off the runway exit drops into the pool. The recommended overhang is 4 inches.
 - C. The minimum depth of water below the exit lip of the slide shall be three feet (3') and increase to four feet six inches (4'-6") at Pt. A, which is a distance of four feet six inches (4'-6") from the exit lip of the slide as shown in **FIG. 8**.
 - D. A minimum depth of four feet six inches (4'-6") shall be maintained at a distance of nine feet (9') along the extended centerline of the slide from Pt. A. as shown in **FIG. 8**.

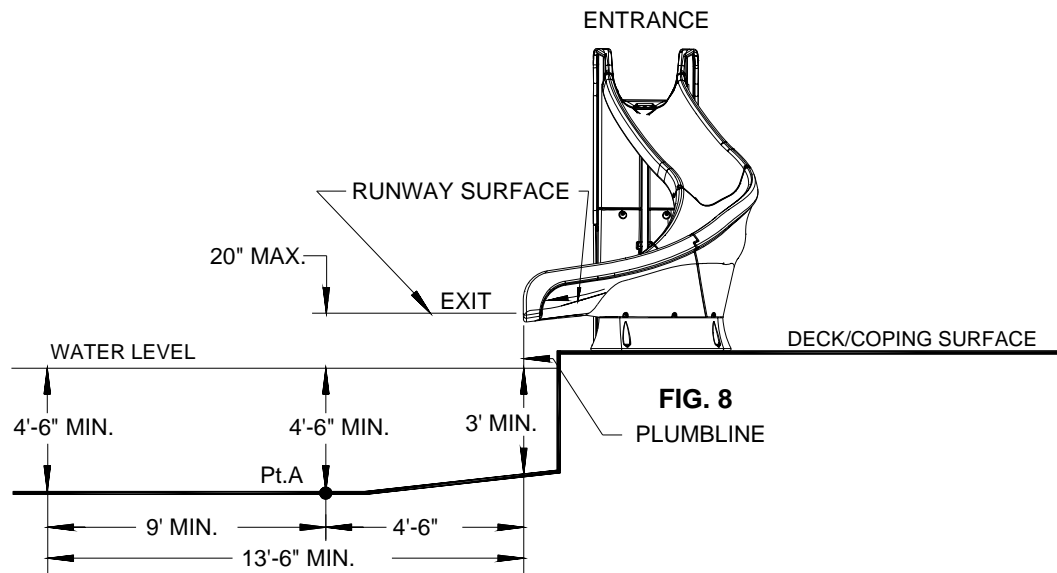

2. A minimum clearance area in front of the slide shall be maintained at all times as follows:

- A. The minimum clearance distance on either side of the extended centerline of the slide runway shall not be less than three feet six inches (3'-6") at a point no less than two feet six inches (2'-6") from the exit lip of the slide and extending a distance of thirteen feet six inches (13'-6") in front of the slide as shown in **FIG. 9**.
- B. The minimum clearance area in front of a properly installed diving board on an inground swimming pool is a minimum distance of three feet six inches (3'-6") on either side of the board's centerline as shown in **FIG. 10**. Pt. C extends a minimum distance of "C" from the tip end of the board as shown in **FIG. 10**. The width distance "W" on either side of Pt. C is given in **CHART 1** and shown in **FIG. 10**.

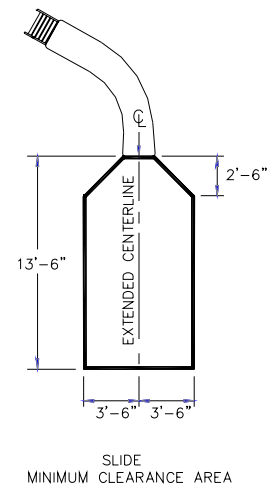

FIG. 9

CHART 1

BOARD MINIMUM CLEARANCE AREA		
POOL TYPE	"C" DIMENSION	"W" DIMENSION
I	14'-6"	5'-0"
II	14'-6"	6'-0"
III	16'-6"	6'-0"
IV	18'-6"	7'-6"
V	21'-0"	7'-6"

See Article 5 contained in ANSI/NSPI-5 2003 STANDARD FOR RESIDENTIAL INGROUND SWIMMING POOLS and refer to FIGURE 3 and Table 1 for Minimum Water Envelope Dimensions AB, BC and Width at Point C.

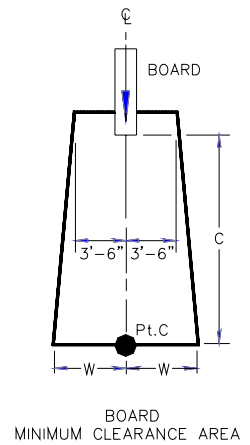

FIG. 10

"C" DIMENSION FOR BOARD = AB + BC
 "W" DIMENSION FOR BOARD = WIDTH AT PT.C

- C. The minimum clearance area of a slide or diving board shall not intersect any coping or rope and float line as shown in **FIG. 11**. The minimum clearance area of a slide or diving board may intersect each other provided that they are not used simultaneously.

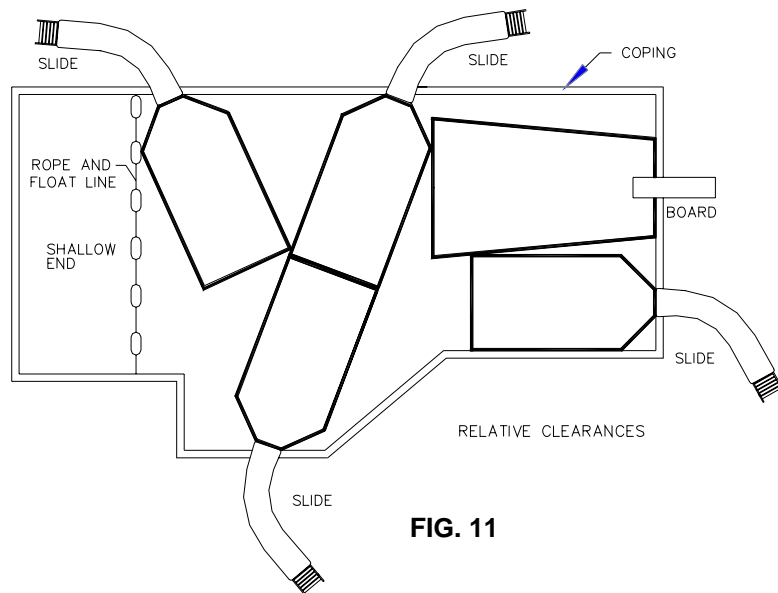

FIG. 11

INSTALLED TURBOTWISTER™ STRUCTURAL & INSTALLATION CHECKLIST

1. Inspect the runway for visible cracks or tears.
2. Inspect the slide for sharp edges, protrusions, cracks or tears.
3. Inspect all fasteners to make sure they are fully tightened.
4. Inspect the ladder for rigidity and attachment.
5. Measure the following dimensions and compare with the Manufacturer's Placement Instructions on pages 6 and 7.
 - Measure the depth of water in front of the slide exit. (4'-6" min. depth at a distance of 4'-6" from exit end of slide.)
 - Measure the height of the slide runway exit above the water. (20" max.)
 - Measure the distance between the slide centerline and the edge of other pool equipment.
6. Observe the position of the exit of the slide as shown in **FIG.'S 8, 9 and 11** on pages 10 and 11.

IMPORTANT

PERSONALLY GIVE TO SLIDE OWNER THE TURBOTWISTER™ OWNER'S MANUAL, THE WARRANTY CARD AND ANSWER ALL QUESTIONS.